

Tiercon EOAT Standard



	Prepared By: M Bisutti	Revision #: 002	Document: QS 27
	Approved by: Jamie Westfall	Rev. Date: December 20, 2022	Page 2 of 14
Procedure: End of Arm Tooling Standard			

End of Arm Tooling (EOAT) Standard

Contents

End of Arm Tooling (EOAT) Standard.....	2
1. Scope	3
2. General	4
3. Drawings, Confidentiality and Design Review	5
4. Design Review.....	6
5. EOAT Common Components	7
6. Electrical and Pneumatic Standards	11
7. EOAT alignment features *Mold, EOAT, Degate	14
8. Vacuum Switches.....	14
9. Press Minimum Required Mold Clearances	15
10. Revision Record Chart.....	18

	Prepared By: M Bisutti	Revision #: 002	Document: QS 27
	Approved by: Jamie Westfall	Rev. Date: December 20, 2022	Page 3 of 14
Procedure: End of Arm Tooling Standard			

1. Scope

- 1.1. Tiercon End of Arm Tooling (EOAT) Standard: Hereinafter may be called the “Specification”.
- 1.2. The scope of this document is to provide general specifications for the design and fabrication of industrial equipment. Tiercon has implemented the “Tiercon EOAT Standard” as a communication tool to ensure that equipment shall be built for maximum safety, performance, and maintainability. This specification shall represent a baseline, which may assist Tiercon employees in policing the design, fabrication and purchase of industrial equipment. This specification is also intended for use by our Suppliers to communicate clearly, Tiercon’s expectations in quality for industrial equipment.
- 1.3. We do not wish to limit the creativity of our suppliers or their suggestions relating to new technology and improved methods of accomplishing our goals. We wish to instill an open line of communication with our suppliers and request that our employees are involved in decisions that may conflict with these specifications.
- 1.4. The “Tiercon EOAT Standard” is intended to promote.
 - Safety
 - Environmental Awareness and Improvements
 - Component Consolidation
 - Minimum Purchase and Operational Costs
 - Focused Supplier Support
 - Conservation of Energy
 - Implementation of New Technology
 - Long Term Planning and Development
 - Equipment Capability and Repeatability
 - Supplier Responsibility
 - Equipment Maintainability
 - Quality of Equipment, Tooling and Fixtures supplied
- 1.5. Tiercon is committed to providing the highest quality End of Arm Tooling (EOAT) in a timely and cost-effective manner. All EOAT must meet all internal Tiercon EH&S requirement, be structurally and mechanically sound as well as being highly capable of providing a quality part with a robust manufacturing process.
- 1.6. The requirements listed below are the minimum acceptable for EOAT to be used at Tiercon/Coplas.

	Prepared By: M Bisutti	Revision #: 002	Document: QS 27
	Approved by: Jamie Westfall	Rev. Date: December 20, 2022	Page 4 of 14
Procedure: End of Arm Tooling Standard			

- 1.7. Tiercon/Coplas is committed to working with our Suppliers to ensure that all EOAT meets or exceeds all internal requirements and expectations.
- 1.8. The standards outlined on the following pages are intended to enhance this partnership by clarifying the expectations regarding standard practices to be used when designing and building Tiercon/Coplas EOAT.
- 1.9. All corresponding information, construction views, drawings and notes are to be considered minimum requirements and must be used in conjunction with generally accepted design and build practices. All dimensions are in imperial units.
- 1.10. NOTE: This standard is NOT intended to eliminate the need for sound engineering judgment. Deviations from these standards are expected when deemed necessary. However, any deviations must be reviewed and approved by Tiercon/Coplas prior to being implemented into a EOAT design and/or system.
- 1.11. The EOAT Supplier of record shall acknowledge the Tiercon/Coplas EOAT Standards in quotes and design reviews.

2. General

- 2.1. All equipment proposals must include reference to the latest revision of the Specification.
- 2.2. The acceptance of the purchase order whether written or verbal shall also deem acceptance of the Specification unless written deviations are submitted.
- 2.3. We wish to work with suppliers that operate in a manner that will help us attain the Tiercon vision, "To be the preferred supplier of injection molded products".
- 2.4. We shall conduct business with preferred suppliers who believe in and demonstrate the following:
 - **Safety** - following the "Occupational Health and Safety Act and Regulations for Industrial establishments", Michigan, United States, Ontario, Canada as well as rules and regulations under the "Ministry of Environment and Energy" (MOEE)
 - Integrity
 - Teamwork
 - Speed
 - Innovation
 - Performance
 - Open communication
 - Lawful and ethical business practice following all the laws of Ontario, Canada and Michigan, USA
 - Quality

	Prepared By: M Bisutti	Revision #: 002	Document: QS 27
	Approved by: Jamie Westfall	Rev. Date: December 20, 2022	Page 5 of 14
Procedure: End of Arm Tooling Standard			

- 2.5. **A penalty clause may be part of the contract for late delivery of equipment.** Tiercon reserves the right to take action against poor quality tools and/or slippage in timing. This may take the form of a tool transfer and/or financial recourse against the supplier.
- 2.6. Tiercon requires equipment and tooling to meet all design and process criteria. In addition, set up, change over, maintenance and troubleshooting must be achieved safely and efficiently.
- 2.7. The equipment shall be designed around a Total Productive Maintenance (TPM) program. Easy access to lubrication points, valves, sensors, motors, etc. must be considered prior to any fabrication and assembly of equipment.
- 2.8. The use of statistics by suppliers to control their own process is desirable. In addition, it is a requirement of every supplier of every piece of equipment to prove to Tiercon that the equipment and tooling is statistically capable and repeatable of meeting all specifications and requirements.
- 2.9. Equipment shall be delivered with documentation and training.
- 2.10. All electrical components shall be CSA/UL and/or Ontario Hydro approved and conforms to OSHA/MIOSHA standards.
- 2.11. This document may be used by itself in whole, or with additional documents in the form of, purchase orders, meeting minutes, Tiercon part design drawings, statistical specifications, plant layout, government documents, etc.
- 2.12. Failure to meet this specification without written approval by Tiercon may result in the supplier being financially responsible for all corrections.
- 2.13. It is the supplier's responsibility to identify additional improvements that may increase the performance of any piece of equipment. Tiercon may offer reward and recognition if the improvements prove positive.
- 2.14. Tool source to provide weekly timelines and pictorial documentation to the Tiercon Tooling Engineer, Program Manager, or other designated Project Lead.

3. Drawings, Confidentiality and Design Review

- 3.1 Drawings
 - 3.1.1 All drawings (Def. drawings; math data, sketches, and/or files) supplied by Tiercon are confidential and property of Tiercon. Drawings are NOT to be copied unless approved by Tiercon. All drawings supplied must be returned to Tiercon at project completion or as requested by a Tiercon employee.
- 3.2 Confidentiality
 - 3.2.1 The supplier shall be required to sign a Confidentiality Agreement prior to any drawings released by Tiercon. This document acts as a binding contract and legal agreement pertaining to all "Confidential Information".

	Prepared By: M Bisutti	Revision #: 002	Document: QS 27
	Approved by: Jamie Westfall	Rev. Date: December 20, 2022	Page 6 of 14
Procedure: End of Arm Tooling Standard			

- 3.2.2 It is standard operating procedure for Tiercon to enter into Confidentiality Agreements with its suppliers. The supplier must be prepared to sign this agreement if requested.
- 3.2.3 When Confidentiality Agreements are signed, all design proposals, and drawings, programs etc. become the property of Tiercon regardless of their physical location.
- 3.2.4 At the written request of Tiercon, equipment shall be designed and fabricated in camera. (Def. in camera; private, behind an enclosure, in secrecy)

4. Design Review

- 4.1. Definition of design approval: This approval is only an acknowledgement by Tiercon to the supplier that the general equipment concept is within the purchase order requirements and that all sections of the specification have been followed. This approval does not wave the responsibility of the supplier to make the equipment function as per the specification criteria established in this document and in additional documents such as the purchase order.
- 4.2. A design review by Tiercon shall be conducted at the detailed design stage. At this time, initial compliance to the Purchase Order will be reviewed and the project team will address the Specification, Safety concerns and Ergonomic issues. (Supplier and Tiercon representatives) At this point, Tiercon may provide approvals to continue.
- 4.3. Further reviews will be determined as needed by the Tiercon Project Manager. (Project/Process Engineer/ Robotics Specialist)
- 4.4. Supplier Responsibility: The supplier shall be responsible to ensure that the design is functional to all parameters documented in the Purchase Order, the Specification and any relative part drawings or layouts. If the supplier develops difficulties with any portion of the contract, it is the supplier’s responsibility to inform Tiercon, in writing, of this difficulty.

	Prepared By: M Bisutti	Revision #: 002	Document: QS 27
	Approved by: Jamie Westfall	Rev. Date: December 20, 2022	Page 7 of 14
Procedure: End of Arm Tooling Standard			

5. EOAT Common Components

Off the shelf items are always preferable, but if custom items need to be fabricated, a sign off by a Tiercon representative must be obtained. At this time it will be determined if spare custom parts must be fabricated to protect production in case of failure.

Component	Oshawa	Coplas	591
Air / Vac Fittings	<u>DJ INDUSTRIAL / PISCO</u> PB 6-01M, PB 4-M5M THREADED "T" PB 4-01M, PB 6-M5M THREADED "T" PC 6-01M, PC 6-M5M STRAIGHT PC 4-01M, PC 4-M5M STRAIGHT PE 6M, PE 4M "T" FITTING PL 6-01M, PL 6-M5M ELBOW PL 4-01M, PL 4-M5M ELBOW PP 6, PP4 PLUG PY6M, PY4M "Y" UNION PZA 6M, PZA 4M CROSS UNION	<u>PISCO</u> PB 6-01M, PB 4-M5M THREADED "T" PB 4-01M, PB 6-M5M THREADED "T" PC 6-01M, PC 6-M5M STRAIGHT PC 4-01M, PC 4-M5M STRAIGHT PE 6M, PE 4M "T" FITTING PL 6-01M, PL 6-M5M ELBOW PL 4-01M, PL 4-M5M ELBOW PP 6, PP4 PLUG PY6M, PY4M "Y" UNION PZA 6M, PZA 4M CROSS UNION	<u>DJ INDUSTRIAL / PISCO</u> PB 6-01M, PB 4-M5M THREADED "T" PB 4-01M, PB 6-M5M THREADED "T" PC 6-01M, PC 6-M5M STRAIGHT PC 4-01M, PC 4-M5M STRAIGHT PE 6M, PE 4M "T" FITTING PL 6-01M, PL 6-M5M ELBOW PL 4-01M, PL 4-M5M ELBOW PP 6, PP4 PLUG PY6M, PY4M "Y" UNION PZA 6M, PZA 4M CROSS UNION
Tubing	<u>DJ INDUSTRIAL / PISCO</u> UBT0425-100-Y 4MM TUBE YELLOW UBT0640-100-Y 6MM TUBE YELLOW UBT0640-100-B 6MM TUBE BLACK UBT0640-100-R 6MM TUBE RED UBT0640-100-O 6MM TUBE ORANGE UBT0640-100-G 6MM TUBE GREEN UBT0640-100-BU 6MM TUBE BLUE UBT0640-100-CB 6MM TUBE CLEAR BLUE UBT0640-100-C 6MM TUBE CLEAR UBT0640-100-W 6MM TUBE WHITE	M4/M6 Pisco	<u>DJ INDUSTRIAL / PISCO</u> UBT0425-100-Y 4MM TUBE YELLOW UBT0640-100-Y 6MM TUBE YELLOW UBT0640-100-B 6MM TUBE BLACK UBT0640-100-R 6MM TUBE RED UBT0640-100-O 6MM TUBE ORANGE UBT0640-100-G 6MM TUBE GREEN UBT0640-100-BU 6MM TUBE BLUE UBT0640-100-CB 6MM TUBE CLEAR BLUE UBT0640-100-C 6MM TUBE CLEAR UBT0640-100-W 6MM TUBE WHITE
Electrical Connector	<u>SESCO</u> PHO1689789 25 PIN SUB D MALE CONNECTOR PHO1689792 CABLE END HOUSING PHO1652127 RUBBER GROMMET & NUT PHO1689750 PANNEL MOUNT HOUSING PHO1689886 25 PIN SUB D CONNECTOR FEMALE	Harting HAN10A 09200102612M/HOOD 19200101540	<u>SESCO</u> PHO1689789 25 PIN SUB D MALE CONNECTOR PHO1689792 CABLE END HOUSING PHO1652127 RUBBER GROMMET & NUT PHO1689750 PANNEL MOUNT HOUSING PHO1689886 25 PIN SUB D CONNECTOR FEMALE

	Prepared By: M Bisutti	Revision #: 002	Document: QS 27
	Approved by: Jamie Westfall	Rev. Date: December 20, 2022	Page 8 of 14
Procedure: End of Arm Tooling Standard			

Component	Oshawa	Coplas	591
Base Plate	<u>SEPRO</u> BP-135 OS1,2,3,6 & 7 <u>MARTECH / ASS COMPATABLE</u> GPM.2X OS4 &5	<u>ASS</u> ASS 1-005-45-00 GPM.3X GPM.2X	<u>SEPRO</u> BP-135 <u>MARTECH / ASS COMPATABLE</u> GPM.2X
Frame Components	<u>GEO T WHITE - ASS</u> 01.07.731 VAC SWITCH ADJUSTABLE ADZ 20-20 CYLINDER ADAPTER ADZ 20-32 CYLINDER ADAPTER DKS X 14-80 90° CLAMP EPL X 2-50-25, EPL X 2-25-25 END CAP EPL X 3-50-25, EPL X 3-25-25 END CAP DESTACO 8115 SWING CLAMP GRF 20-95 GRIPPER FINGER COATED GRZ AD 20-16 GRIPPER ADAPTER KVB X 50-25 CROSS JOINT CONNECTOR KHZ 20-5-DA SHORT STROK CYLINDER KHZ 20-20 DA SHORT STROK CYLINDER KHZ 20-30 AD SHORT STROK CYLINDER KVB L 10 CROSS CLAMP VLR 20-150 ARM EXTENSION WIV X 25 ANGLE JOINT CONNECTORS <u>MARTECH / ASS COMPATABLE</u> CA.GAZ.2020.60 CYLINDER MOUNTING ARM CA.GAZ.2020.100 CYLINDER MOUNTING ARM CA.GAZ.3220.60 CYLINDER MOUNTING ARM CA. GAZ.3220.100 CYLINDER MOUNTING ARM CA.GWPM5 CHANNEL NUT CA.KBVX.2510 CROSS JOINT CONNECTORS CA.KBVL.1818 CROSS JOINT CONNECTORS CA.KBVX1825 CROSS JOINT CONNECTORS CA.KBVX2525 CROSS JOINT CONNECTORS CA.KPLX.2525 CROSS JOINT CONNECTORS CA.KPLX.5025 CROSS JOINT CONNECTORS CA.KPLX.2518 CROSS JOINT CONNECTORS CA.KVB.X14 CROSS CLAMP CA.KVB.X20 CROSS CLAMP	<u>GEO T WHITE - ASS</u> 01.07.731 VAC SWITCH ADJUSTABLE ADZ 20-20 CYLINDER ADAPTER ADZ 20-32 CYLINDER ADAPTER DKS X 14-80 90° CLAMP EPL X 2-50-25, EPL X 2-25-25 END CAP EPL X 3-50-25, EPL X 3-25-25 END CAP DESTACO 8115 SWING CLAMP GRF 20-95 GRIPPER FINGER COATED GRZ AD 20-16 GRIPPER ADAPTER KVB X 50-25 CROSS JOINT CONNECTOR KHZ 20-5-DA SHORT STROK CYLINDER KHZ 20-20 DA SHORT STROK CYLINDER KHZ 20-30 AD SHORT STROK CYLINDER KVB L 10 CROSS CLAMP VLR 20-150 ARM EXTENSION WIV X 25 ANGLE JOINT CONNECTORS <u>MARTECH / ASS COMPATABLE</u> CA.GAZ.2020.60 CYLINDER MOUNTING ARM CA.GAZ.2020.100 CYLINDER MOUNTING ARM CA.GAZ.3220.60 CYLINDER MOUNTING ARM CA. GAZ.3220.100 CYLINDER MOUNTING ARM CA.GWPM5 CHANNEL NUT CA.KBVX.2510 CROSS JOINT CONNECTORS CA.KBVL.1818 CROSS JOINT CONNECTORS CA.KBVX1825 CROSS JOINT CONNECTORS CA.KBVX2525 CROSS JOINT CONNECTORS CA.KPLX.2525 CROSS JOINT CONNECTORS CA.KPLX.5025 CROSS JOINT CONNECTORS CA.KPLX.2518 CROSS JOINT CONNECTORS CA.KVB.X14 CROSS CLAMP CA.KVB.X20 CROSS CLAMP	<u>GEO T WHITE - ASS</u> 01.07.731 VAC SWITCH ADJUSTABLE ADZ 20-20 CYLINDER ADAPTER ADZ 20-32 CYLINDER ADAPTER DKS X 14-80 90° CLAMP EPL X 2-50-25, EPL X 2-25-25 END CAP EPL X 3-50-25, EPL X 3-25-25 END CAP DESTACO 8115 SWING CLAMP GRF 20-95 GRIPPER FINGER COATED GRZ AD 20-16 GRIPPER ADAPTER KVB X 50-25 CROSS JOINT CONNECTOR KHZ 20-5-DA SHORT STROK CYLINDER KHZ 20-20 DA SHORT STROK CYLINDER KHZ 20-30 AD SHORT STROK CYLINDER KVB L 10 CROSS CLAMP VLR 20-150 ARM EXTENSION WIV X 25 ANGLE JOINT CONNECTORS <u>MARTECH / ASS COMPATABLE</u> CA.GAZ.2020.60 CYLINDER MOUNTING ARM CA.GAZ.2020.100 CYLINDER MOUNTING ARM CA.GAZ.3220.60 CYLINDER MOUNTING ARM CA. GAZ.3220.100 CYLINDER MOUNTING ARM CA.GWPM5 CHANNEL NUT CA.KBVX.2510 CROSS JOINT CONNECTORS CA.KBVL.1818 CROSS JOINT CONNECTORS CA.KBVX1825 CROSS JOINT CONNECTORS CA.KBVX2525 CROSS JOINT CONNECTORS CA.KPLX.2525 CROSS JOINT CONNECTORS CA.KPLX.5025 CROSS JOINT CONNECTORS CA.KPLX.2518 CROSS JOINT CONNECTORS CA.KVB.X14 CROSS CLAMP CA.KVB.X20 CROSS CLAMP

	Prepared By: M Bisutti	Revision #: 002	Document: QS 27
	Approved by: Jamie Westfall	Rev. Date: December 20, 2022	Page 9 of 14
Procedure: End of Arm Tooling Standard			

Component	Oshawa	Coplas	591
Frame Components	CA.VLR.20.100 ARM EXTENSIONS CA.VLR.20.50 ARM EXTENSIONS CA.VLR.14.120 ARM EXTENSIONS CA.VTB.X.181818 VACUUM MANIFOLD CA.WKA.20.20.150 ANGLE ARM CA.WKA.20.20.100 ARM EXTENSIONS CA.WKA.20.20.50 ARM EXTENSIONS CA.WKA.14.14.120 ARM EXTENSIONS CA.WKA.14.14.80 ARM EXTENSIONS CA.WKA.14.14.40 ARM EXTENSIONS CA.WKA.10.10.90 ARM EXTENSIONS CA.WKA.10.10.60 ARM EXTENSIONS CA.WKA.10.10.30 ARM EXTENSIONS <u>HASCO</u> For molds in over 500 t press Z0512/20	CA.VLR.20.100 ARM EXTENSIONS CA.VLR.20.50 ARM EXTENSIONS CA.VLR.14.120 ARM EXTENSIONS CA.VTB.X.181818 VACUUM MANIFOLD CA.WKA.20.20.150 ANGLE ARM CA.WKA.20.20.100 ARM EXTENSIONS CA.WKA.20.20.50 ARM EXTENSIONS CA.WKA.14.14.120 ARM EXTENSIONS CA.WKA.14.14.80 ARM EXTENSIONS CA.WKA.14.14.40 ARM EXTENSIONS CA.WKA.10.10.90 ARM EXTENSIONS CA.WKA.10.10.60 ARM EXTENSIONS CA.WKA.10.10.30 ARM EXTENSIONS <u>HASCO</u> For molds in over 500 t press Z0512/20	CA.VLR.20.100 ARM EXTENSIONS CA.VLR.20.50 ARM EXTENSIONS CA.VLR.14.120 ARM EXTENSIONS CA.VTB.X.181818 VACUUM MANIFOLD CA.WKA.20.20.150 ANGLE ARM CA.WKA.20.20.100 ARM EXTENSIONS CA.WKA.20.20.50 ARM EXTENSIONS CA.WKA.14.14.120 ARM EXTENSIONS CA.WKA.14.14.80 ARM EXTENSIONS CA.WKA.14.14.40 ARM EXTENSIONS CA.WKA.10.10.90 ARM EXTENSIONS CA.WKA.10.10.60 ARM EXTENSIONS CA.WKA.10.10.30 ARM EXTENSIONS <u>HASCO</u> For molds in over 500 t press Z0512/20
Sprue Gripper	<u>MARTECH / ASS COMPATABLE</u> CA.GRZ.20.W PNP GRIPPER CA.GRZ.20.WN NPN GRIPPER CA.GZA.10.12.S9 PNP GRIPPER CA.GZA.10.12.S9N NPN GRIPPER	EMI GRZ-20-16-C-P8/ASS ASS GRZ.1012.CS	<u>MARTECH / ASS COMPATABLE</u> CA.GRZ.20.W PNP GRIPPER CA.GRZ.20.WN NPN GRIPPER CA.GZA.10.12.S9 PNP GRIPPER CA.GZA.10.12.S9N NPN GRIPPER
Vacuum Grippers	<u>ICS / JOULIN</u> FG.PG.GS80.REG.2ST 80MM 2 STAGE GRIPPER FGF.GS80.24.US.16 80mm FOAM REPLACEMENT	<u>JOULIN</u> FG.PG.GS80.REG.2ST 80MM 2 STAGE GRIPPER FGF.GS80.24.US.16 80mm FOAM REPLACEMENT	<u>ICS / JOULIN</u> FG.PG.GS80.REG.2ST 80MM 2 STAGE GRIPPER FGF.GS80.24.US.16 80mm FOAM REPLACEMENT
Parallel Gripper	<u>EMI / GIMATIC</u> HS-2518 6472 GIMATIC PARALLEL GRIPPER OFX14-06 5840 Gimatic Parallel Finger Gripper OF20-10 6598 Gimatic Parallel Finger Gripper	<u>EMI / GIMATIC</u> HS-2518 6472 GIMATIC PARALLEL GRIPPER OFX14-06 5840 Gimatic Parallel Finger Gripper OF20-10 6598 Gimatic Parallel Finger Gripper	<u>EMI / GIMATIC</u> HS-2518 6472 GIMATIC PARALLEL GRIPPER OFX14-06 5840 Gimatic Parallel Finger Gripper OF20-10 6598 Gimatic Parallel Finger Gripper
QUICK CONNECT AIR VAC	<u>DJ INDUSTRIAL / PISCO</u> PQ.6M-A, PQ.4M-A EOAT CONNECTOR PQ.6M-B, PQ.4M-B ROBOT CONNECTOR QB-T SERIAL CONNECTOR These are for OS1, 4, 5 & 7 <u>SEPRO</u> AP00000033 MALE EOAT CONNECTOR (Parker) AP00000032 FEMALE ROBOT CONNECTOR (Parker) These are for OS3 & 6	PQ.6M-A, PQ.4M-A EOAT CONNECTOR PQ.6M-B, PQ.4M-B ROBOT CONNECTOR	<u>DJ INDUSTRIAL / PISCO</u> PQ.6M-A, PQ.4M-A EOAT CONNECTOR PQ.6M-B, PQ.4M-B ROBOT CONNECTOR QB-T SERIAL CONNECTOR <u>SEPRO</u> AP00000033 MALE EOAT CONNECTOR (Parker) AP00000032 FEMALE ROBOT CONNECTOR (Parker)

	Prepared By: M Bisutti	Revision #: 002	Document: QS 27
	Approved by: Jamie Westfall	Rev. Date: December 20, 2022	Page 10 of 14
Procedure: End of Arm Tooling Standard			

Component	Oshawa	Coplas	591
Suction cups	<u>GEO T WHITE / PIAB</u> B8.10.01AB VACUUM CUP WITH FITTING B10-2.20.01 AC VACUUM CUP WITH FITTING B15-2.20.01 AC VACUUM CUP WITH FITTING B20-31.50.25 S VACUUM CUP WITH FITTING B30-31.50.026 S VACUUM CUP WITH FITTING B40-31.50.027 S VACUUM CUP WITH FITTING B50-2 32.50.035 S VACUUM CUP WITH FITTING VS 0-10X30HE8 OVAL HIGH TEMP SUCTION CUP F20.20.02AD SILICONE CUP WITH G1/8 MALE FC50.5C.05UB SILICONE CUP WITH G1/8 MALE FC75P.4C.07UF SILICONE CUP WITH G1/8 MALE	<u>GEO T WHITE / PIAB</u> B8.10.01AB VACUUM CUP WITH FITTING B10-2.20.01 AC VACUUM CUP WITH FITTING B15-2.20.01 AC VACUUM CUP WITH FITTING B20-31.50.25 S VACUUM CUP WITH FITTING B30-31.50.026 S VACUUM CUP WITH FITTING B40-31.50.027 S VACUUM CUP WITH FITTING B50-2 32.50.035 S VACUUM CUP WITH FITTING VS 0-10X30HE8 OVAL HIGH TEMP SUCTION CUP F20.20.02AD SILICONE CUP WITH G1/8 MALE FC50.5C.05UB SILICONE CUP WITH G1/8 MALE FC75P.4C.07UF SILICONE CUP WITH G1/8 MALE	<u>GEO T WHITE / PIAB</u> B8.10.01AB VACUUM CUP WITH FITTING B10-2.20.01 AC VACUUM CUP WITH FITTING B15-2.20.01 AC VACUUM CUP WITH FITTING B20-31.50.25 S VACUUM CUP WITH FITTING B30-31.50.026 S VACUUM CUP WITH FITTING B40-31.50.027 S VACUUM CUP WITH FITTING B50-2 32.50.035 S VACUUM CUP WITH FITTING VS 0-10X30HE8 OVAL HIGH TEMP SUCTION CUP F20.20.02AD SILICONE CUP WITH G1/8 MALE FC50.5C.05UB SILICONE CUP WITH G1/8 MALE FC75P.4C.07UF SILICONE CUP WITH G1/8 MALE
Extrusion	<u>GEO T WHITE / ASS</u> L 18-10-1000 SMALL ALUMINUM PROFILE L 18-18-1000 SMALL ALUMINUM PROFILE X 25-18-1000 SMALL ALUMINUM PROFILE X 50/25/2000 ALUMINUM X PROFILE <u>MARTECH / ASS COMPATIBLE</u> CA.X.2525.2000 ALUMINUM X PROFILE	ASS	<u>GEO T WHITE / ASS</u> L 18-10-1000 SMALL ALUMINUM PROFILE L 18-18-1000 SMALL ALUMINUM PROFILE X 25-18-1000 SMALL ALUMINUM PROFILE X 50/25/2000 ALUMINUM X PROFILE <u>MARTECH / ASS COMPATIBLE</u> CA.X.2525.2000 ALUMINUM X PROFILE
Adapter Reducer Fittings	<u>GEO T WHITE / ASS</u> RNK M3-M5 RNK 1/8-1/4 RNK M5-1/8 RNK M5-1/4 PDN M5-M5 PDN 1/8-1/8 PDN 1/4 - 1/4 PDN 1/8-M5 PDN 1/4-1/8 <u>MARTECH / ASS COMPATIBLE</u> CA.08.14.21 M5 X M5 MALE ADAPTER	CA.08.14.xx reducing union and male adapter	<u>GEO T WHITE / ASS</u> RNK M3-M5 RNK 1/8-1/4 RNK M5-1/8 RNK M5-1/4 PDN M5-M5 PDN 1/8-1/8 PDN 1/4 - 1/4 PDN 1/8-M5 PDN 1/4-1/8 <u>MARTECH / ASS COMPATIBLE</u> CA.08.14.21 M5 X M5 MALE ADAPTER

	Prepared By: M Bisutti	Revision #: 002	Document: QS 27
	Approved by: Jamie Westfall	Rev. Date: December 20, 2022	Page 11 of 14
Procedure: End of Arm Tooling Standard			

6. Electrical and Pneumatic Standards

6.1. Ranger (OS1 and IMM6)

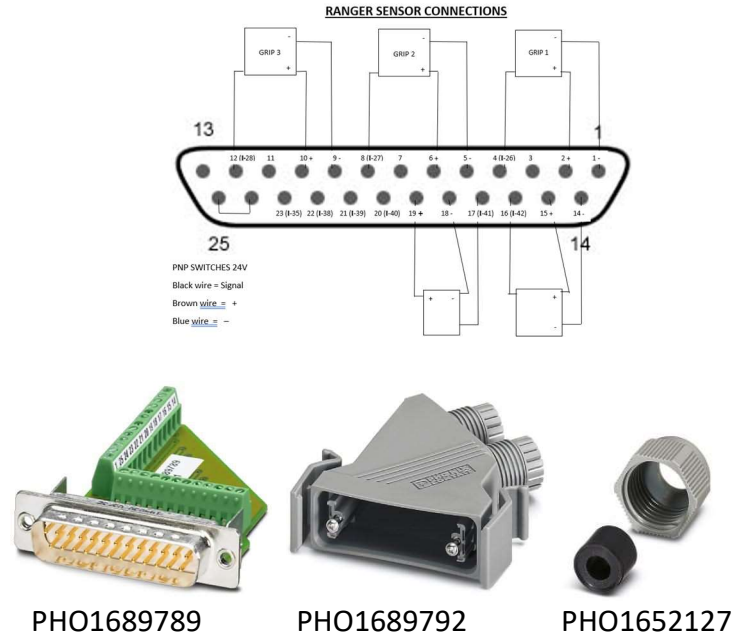
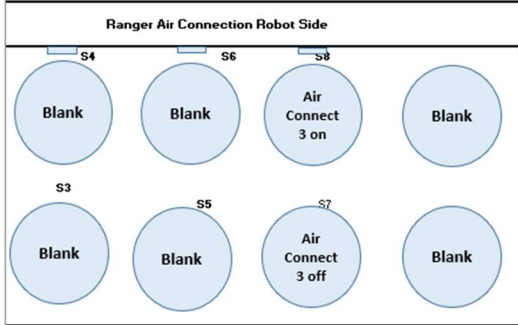
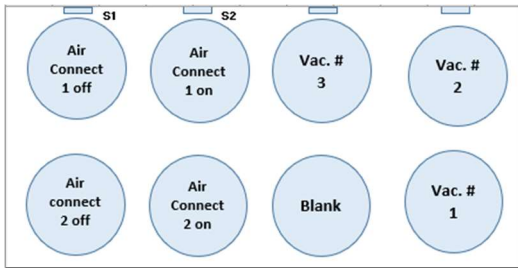

6.2. Sepro (OS2 and IMM2_3)

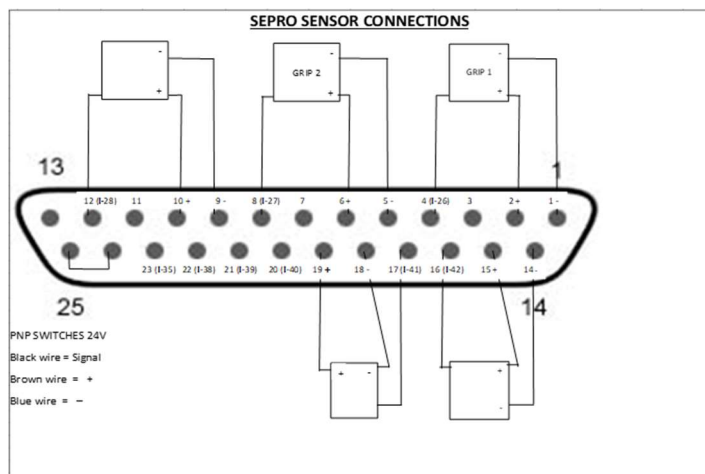
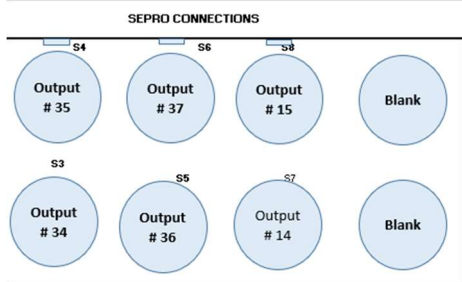
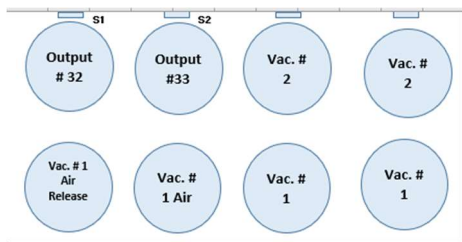

	Prepared By: M Bisutti	Revision #: 002	Document: QS 27
	Approved by: Jamie Westfall	Rev. Date: December 20, 2022	Page 12 of 14
Procedure: End of Arm Tooling Standard			

6.3. Visual 3 (OS3_OS6)

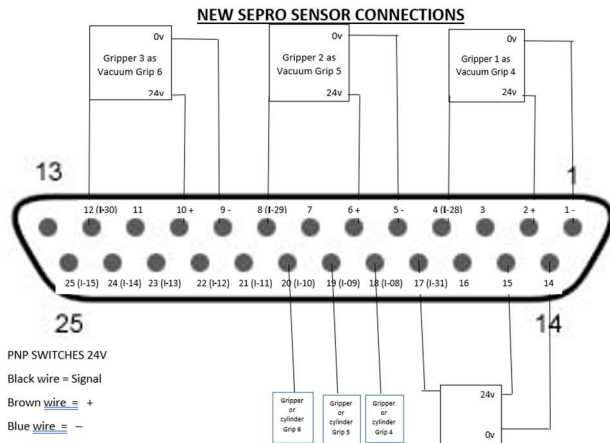
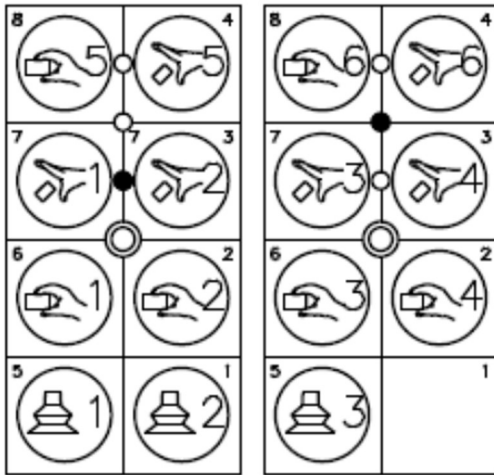

R011834-01

6.4. ABB (OS5)

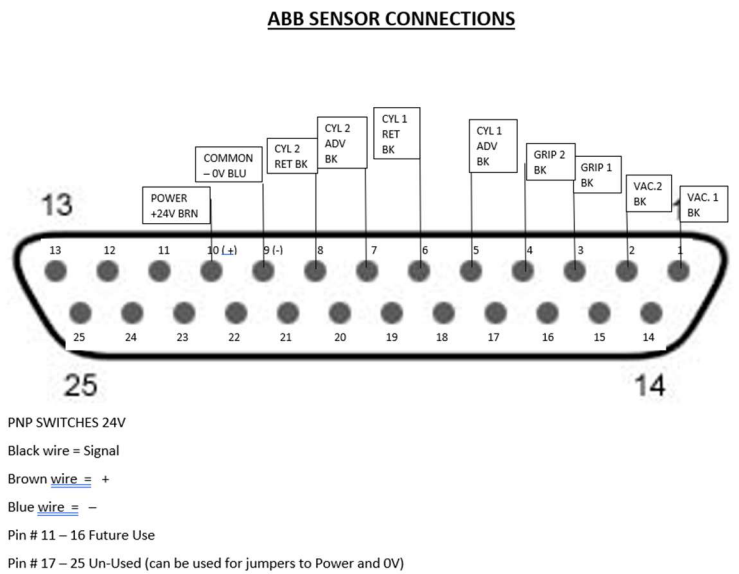
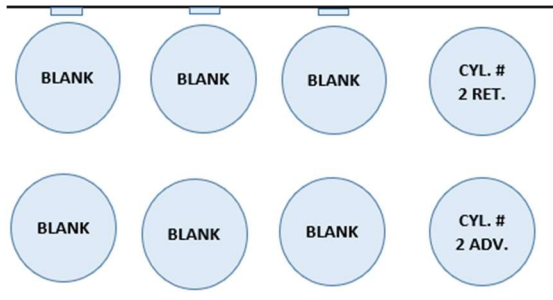
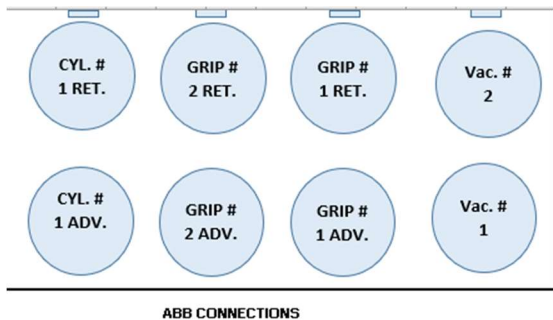

	Prepared By: M Bisutti	Revision #: 002	Document: QS 27
	Approved by: Jamie Westfall	Rev. Date: December 20, 2022	Page 13 of 14
Procedure: End of Arm Tooling Standard			

6.5. Yushin (OS7)

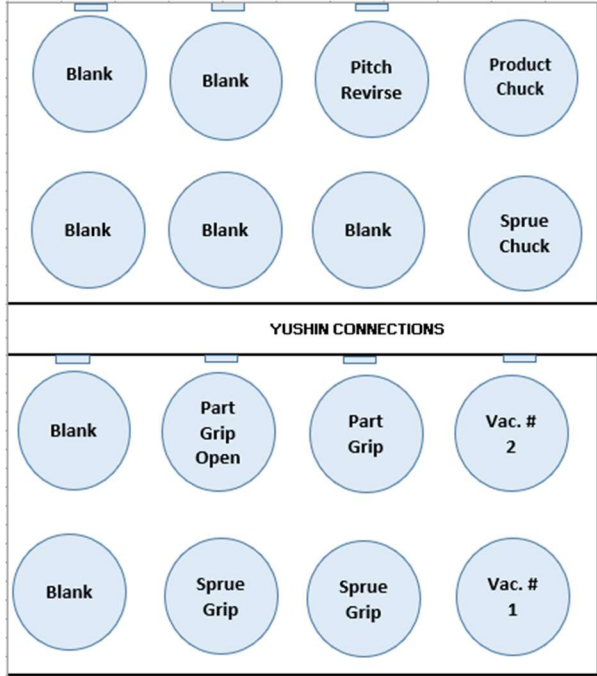

6.6. FANUC (Coplax)

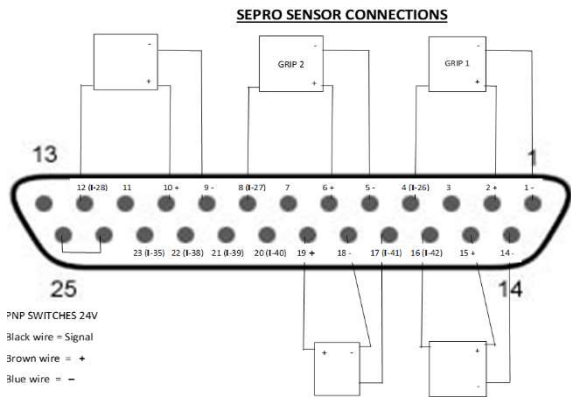

Harting 09200102612

Hood 19200101540

	Prepared By: M Bisutti	Revision #: 002	Document: QS 27
	Approved by: Jamie Westfall	Rev. Date: December 20, 2022	Page 14 of 14
Procedure: End of Arm Tooling Standard			

7. EOAT alignment features *Mold, EOAT, Degate

Hasco - Z0511/... mold side and Degater Z0512/... eoat side

HASCO
Ermöglichen mit System.

Z051/...
Z0511/...
Z0512/...

Zentriereinheit, rund
Locating unit, round
Plot de centrage



8. Vacuum Switches

7.1. Vacuum Signal Switches may be used if necessary (more circuits than the robot has). Grippers switches are to be used. However Multiple switches for the same signal must be wired through a logic box to be mounted on the EOAT.

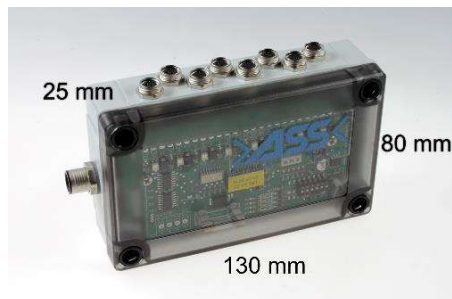

Acceptable vacuum switches.

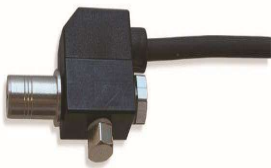

PIAB Vac Switch Adjustable



PIAB Vac Switch preset

	Prepared By: M Bisutti	Revision #: 002	Document: QS 27
	Approved by: Jamie Westfall	Rev. Date: December 20, 2022	Page 15 of 14
Procedure: End of Arm Tooling Standard			

9. Press Minimum Required Mold Clearances

- 8.1. EOAT depth must be smaller than the minimum mold clearance, which is Mold Thickness-Press Opening (Daylight) in Inches
- 8.2. Vendor must contact Tiercon / Coplas Program Management and Project Engineering Team if this cannot be met and Tiercon / Coplas will determine the EOAT's compatibility to the press.

Plant	M/C #	Robot Brand	Clamp Force (US Tons)	Controller Model	Daylight	Model #	Lifting Capacity
Stoney	IMM-1	Husky	2200		141.7	Tracer	
Stoney	IMM-2	Sepro	750	9000 II	79.5	3041	35 kgs
Stoney	IMM-2	Sepro	750	Visual 3	79.5	?	
Stoney	IMM-3	Sepro	2200	Visual 3	115	7X55	55 kgs
Stoney	IMM-4	ABB	1488 shelf	S4C+	122	IRB 6400S	120 kgs
Stoney	IMM-7*	Wittmann	650	TEACH BOX	42.1		
Stoney	IMM-5	Wittmann	1750	TEACH BOX	129.9	w753c	
Stoney	IMM-6	Ranger	1500	TouchScreen	124	RTF-2000S5	55 kgs
Stoney	IMM-8	Wittmann	720	TEACH BOX	78.7	w6741	

	Prepared By: M Bisutti	Revision #: 002	Document: QS 27
	Approved by: Jamie Westfall	Rev. Date: December 20, 2022	Page 16 of 14
Procedure: End of Arm Tooling Standard			

Plant	M/C #	Robot Brand	Clamp Force (US Tons)	Controller Model	Daylight	Model #	Lifting Capacity
Oshawa	OS-1	Ranger	1450	5 Axis YAS	106.2	RTF-2000S5	55 kgs
Oshawa	OS-2	Sepro	2200	9000 II	137.6	3061	55 kgs
Oshawa	OS-3	Sepro	2200	Visual 3	137.6	7X55LV	55 kgs
Oshawa	OS-4	Engel	300	RC 511	49.6	ERC 33/1-ERC100	15 kgs
Oshawa	OS-5	ABB	500	S4C+	55.1	IRB 2400/16 M2000	9 kgs
Oshawa	OS-6	Sepro	990	Visual 3	82.3	7X55	55 kgs
Oshawa	OS-6	ABB	degate	S4C+	82.3	IRB 2400/16 M98A	9 kgs
Oshawa	OS-7	Yushin	500	VNIIEA Series	55.1	VNII-EA-550SLL-16	15 kgs

	Prepared By: M Bisutti	Revision #: 002	Document: QS 27
	Approved by: Jamie Westfall	Rev. Date: December 20, 2022	Page 17 of 14
Procedure: End of Arm Tooling Standard			

Plant	M/C #	Robot Brand	Clamp Force (US Tons)	Controller Model	Daylight	Model #	Lifting Capacity
Coplas	SH-1	Sepro	1100	Vision	94.5	Vision Series 3051	45 kgs
Coplas	SH-2	Fanuc	2200	RJ3iB	137.5	R-2000iA/165F	
Coplas	SH-2	Fanuc	degate	RJ3iB	137.5	ArcMate 120iB	
Coplas	SH-3	Fanuc	1450 shelf	R30iA	106.2	R-2000iB/100P	
Coplas	SH-3	Fanuc	degate	R30iA	106.2	M20iA	
Coplas	SH-4	Fanuc	2200	RJ3	137.7	S-430i F A05B-1321-B201	
Coplas	SH-4	Fanuc	degate	RJ3	137.7	ArcMate 100i	
Coplas	SH-5	Fanuc	1800 shelf	RJ3iB	122	R-2000iA/200R	
Coplas	SH-5	Fanuc	degate	RJ3iB	122	ArcMate 120iB	
Coplas	SH-6	Fanuc	2200	RJ3	138.8	R-2000iA/165F	
Coplas	SH-6	Fanuc	degate	RJ3	138.8	ArcMate 100i	
Coplas	SH-7	Fanuc	2200 shelf	R30iA	124	R-2000iB/100P	
Coplas	SH-7	Fanuc	degate	R30iA	124	M20iA	
10 Mile	EP-1	Sytrama Roboline	500		?	?	
10 Mile	EP-2	ABB	610	S4C+	62.9	IRB 2400/16 M98A	

	Prepared By: M Bisutti	Revision #: 002	Document: QS 27
	Approved by: Jamie Westfall	Rev. Date: December 20, 2022	Page 18 of 14
Procedure: End of Arm Tooling Standard			

10. Revision Record Chart

<i>Revision</i>	<i>Date</i>	<i>Details of Change</i>	<i>Revised By</i>
0	Mar 10/2022	Original created	Mark Bisutti
1	Sept 21/2022	Update EoaT components and vacuum switch sections	Mark Bisutti
2	Dec 20/2022	Images added, centering units added to Frame Components	Mark Bisutti
3	Jan 30/2023	Images added to Vacuum Switch section	Mark Bisutti